



BH1EU3000

Gato de carretilla, 3 T



DETALLES DEL PRODUCTO

- Gato de carretilla compacto 3 T
- Acceso con una altura de 130 mm y una altura alcanzable de elevación de 462 mm
- Sistema de doble pistón que permite alcanzar la altura máxima en siete golpes de bomba
- Equipado con ruedas de nailon
- Cubierta antipolvo que protege los pistones y el muelle
- Montura de goma que protege las superficies del vehículo y evita deslizamientos
- Foam en el mango que evita que se dañe la carrocería del vehículo
- Equipado con un sistema de control de la velocidad de descenso y una válvula de presión de seguridad
- Certificado CE de acuerdo con la normativa 2006/42/CE + BS EN1494

Ref.	h1	h2
BH1EU3000	195	250
BH11500	145	200
BH12000	145	200
BH13000	165	220
BH13000QA	170	225

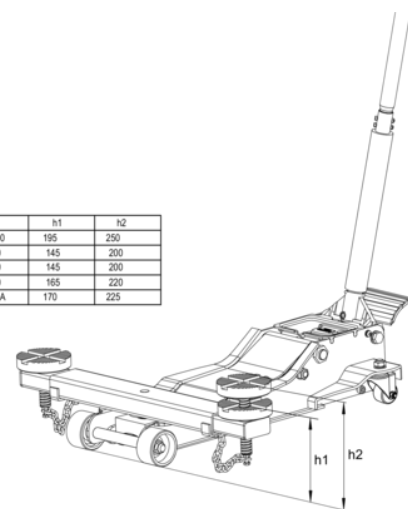

Follow the Fish!



ATRIBUTOS DE PRODUCTO

Producto: **BH1EU3000**

	3000 kg		130 mm		462 mm
	617 mm		6		120 mm
			617 mm		340 mm
	1400 mm		31 kg		

Follow the Fish!

